

# User Manual

# 3D MANIPULATOR

Accessory for UZ15 Rapid, UZ18 Hardworker and  
UZ12 Ultralight bevelling machines.

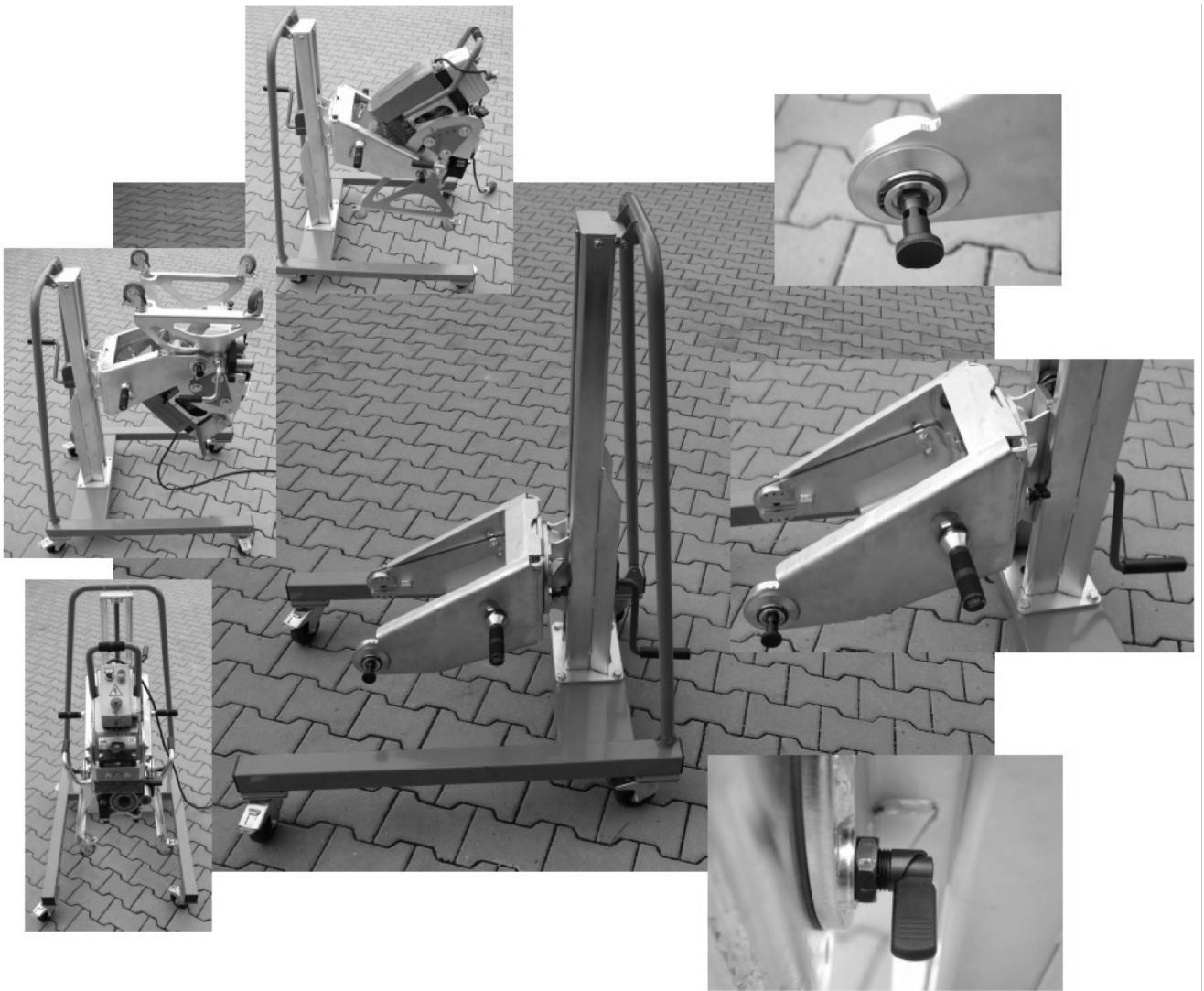

## Quality certificate

Congratulations on purchasing this high-quality product manufactured by N.KO spol s r.o. The product has undergone an internal inspection at the end of the production process and is of a high technical standard. N.KO guarantees the requisite quality for all the uses listed below.

In the event of any defect contact your supplier and present the receipt for your 3D Manipulator.

## General description

The 3D Manipulator is an industrial manipulation system developed as an accessory for the UZ15 Rapid, UZ18 Hardworker and UZ12 Ultralight bevelling systems (only with special adapters – see the UZ12 Ultralight catalogue sheet) .

It is prohibited to use this device for any purpose other than that specified in this manual and it is also prohibited to use the 3D Manipulator with any equipment other than the UZ15 Rapid, UZ18 Hardworker and UZ12 Ultralight.

The 3D Manipulator is designed for manipulating, positioning and moving the UZ15 Rapid, UZ18 Hardworker and UZ12 Ultralight bevelling systems.

It is not complicated to work with the system. It may be operated by one person.

The operator must abide by all the relevant safety standards prescribed for work with this system. The instructions in this user manual must also be followed.

## Technical data

Weight of 3D Manipulator:	85 kg
Delivery dimensions (wooden crate):	1240 x 600 x 840 mm
Dimensions of assembled 3D Manipulator:	

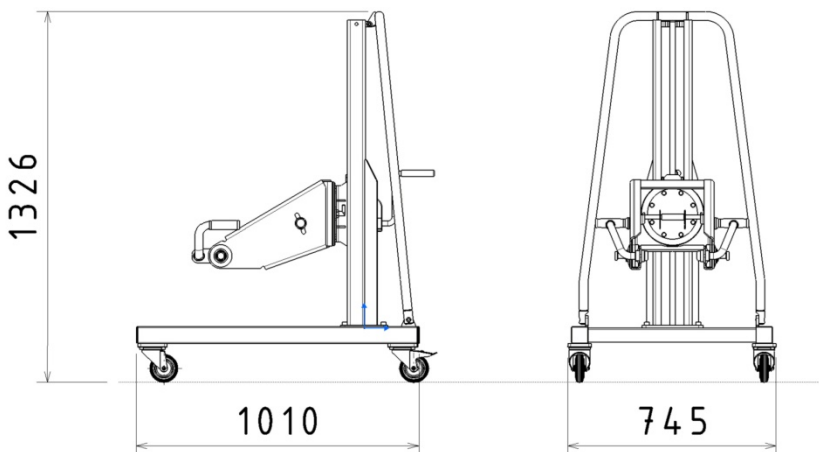

## Transport and assembly

To facilitate storage and transport the 3D Manipulator is supplied in a wooden crate, partially assembled.

Chassis	pos. 1
Stand	pos. 2
Stand cover	pos. 3
Handle	pos. 4
Trolley with turntable / adapter	pos. 5
Castors (4)	pos. 7

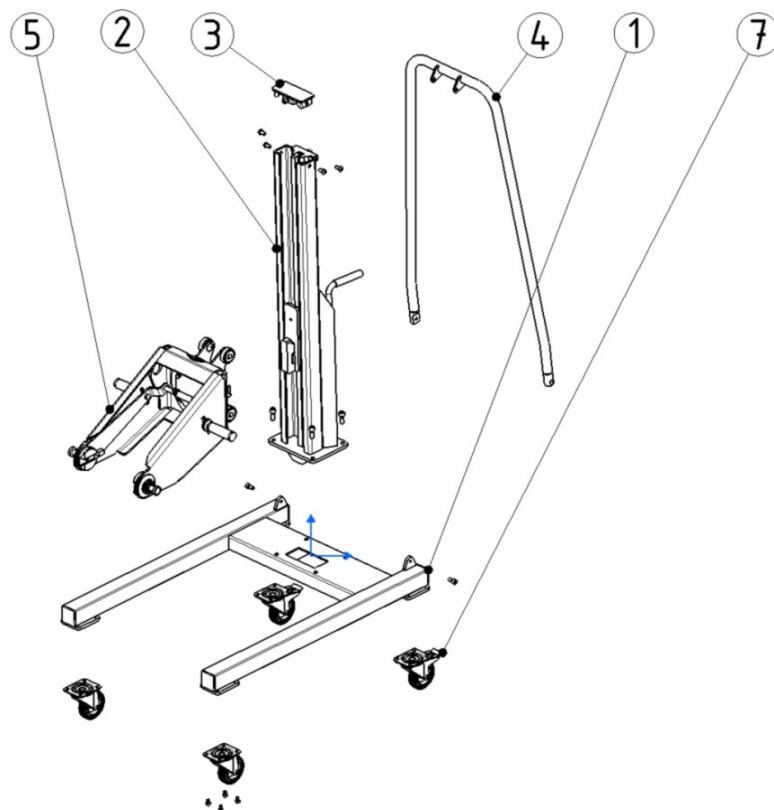

### Procedure for assembling 3D Manipulator:

1. Attach the four rotating braked transport castors (M8x15 screws) to the chassis (pos. 1). Before proceeding any further, the BRAKE MUST BE APPLIED to all four transport castors!
2. Fit the stand (pos. 2) onto the assembled chassis. Use M12x30 screws.
3. Now install the handle (pos. 4) onto the chassis and stand. Use screws (M10x20)
4. Now slide the trolley/adapter with turntable (pos. 5) into the stand from above. Secure the trolley/adapter to prevent the stand cover (pos. 3) from sliding out; screw the stand cover to the top of the stand (M10x20 screw).  
The trolley/adapter must be installed in the right position in the stand (see Fig. 1)  
Before installing the trolley, secure the machine rotating mechanism to prevent it from turning (locking pin). Otherwise there is the risk of injury!

Fig. 1

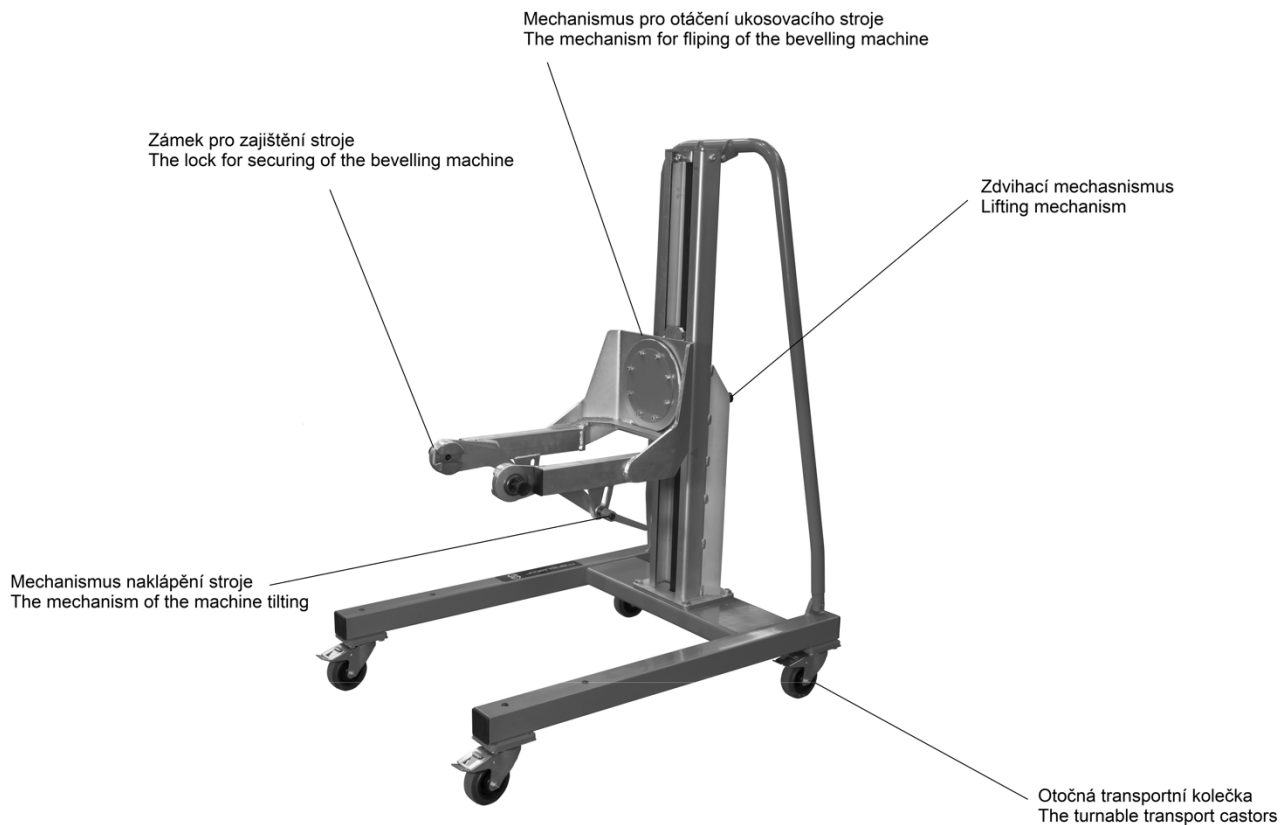

## Detailed description of 3D Manipulator and setup options

The 3D Manipulator is designed for manipulating, positioning and moving the UZ15 Rapid, UZ18 Hardworker and UZ12 Ultralight bevelling systems (only with special adapters - see UZ12 Ultralight catalogue sheet).

The Manipulator is designed for three types of use:

1. The 3D Manipulator is designed for situations when you have to machine large, difficult-to-handle workpieces (sheet metal, profiles...), which are placed on supports.
2. The 3D Manipulator can be used as a stationary holder for the bevelling machine when machining small products (sheet metal, profiles...), which are inserted manually directly into the machine.
3. The 3D Manipulator can be used as a positioner for adjustment and service work on bevelling machines.

## Connecting the 3D Manipulator and bevelling machine

1. Use the lifting mechanism (see Fig. 1.) to set the height of the clamping jaws to the same height as the bevelling machine clamping adapters.
2. Release the locking pins on both sides of the clamping jaws (see Fig. 1.)
3. Release the tilting mechanism (see Fig. 1.) to enable the level of the clamping jaws to be adjusted to the level of the clamping adapters.
4. Apply gradual pressure to the 3D Manipulator to slide the 3D Manipulator clamping jaws onto the bevelling machine clamping adapters and, when correctly in place, secure them with pins on both sides of the 3D Manipulator clamping jaws (see Fig. 1.). If the pins do not fit in the prepared holes, the 3D MANIPULATOR must not be used.

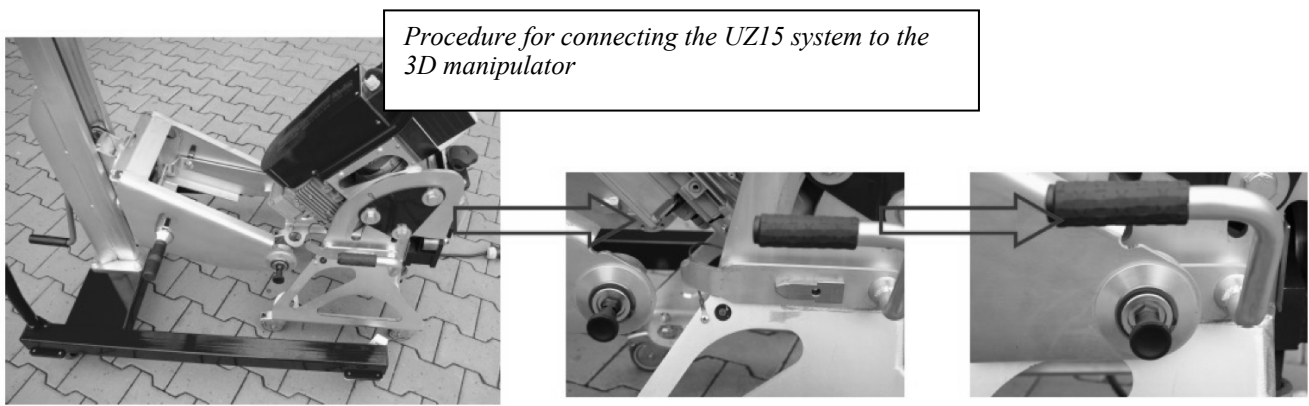

## Calibration of the connection between the bevelling machine and 3D Manipulator (applicable only for older versions manufactured prior to 2018)

Each UZ15 Rapid, UZ18 Hardworker or UZ12 Ultralight and each 3D Manipulator has certain permitted dimensional variations. In certain cases it may happen that the machine cannot be connected to the 3D Manipulator. The reason for this may be a different spacing between the clamping adapters and clamping jaws. This can be corrected using washers (pos. 1 - see illustration below text), which are fitted as needed outside or inside the clamping jaws, thus adjusting the spacing between the 3D Manipulator by approx. 4-6mm.

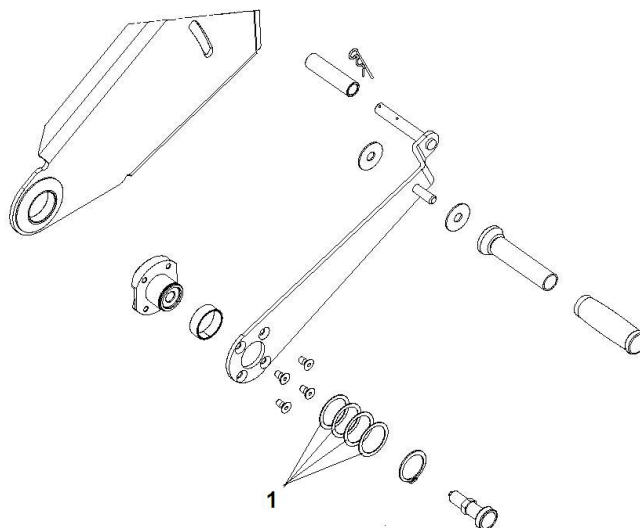

## Working with the 3D Manipulator

**Procedure for machining larger parts** (the 3D Manipulator moves along the workpiece) Move the 3D Manipulator with the clamped bevelling system to the sheet to be machined, which should be placed on supports and as level as possible. If there are any waves or deformations in the machined material, the 3D Manipulator system cannot be guaranteed to work properly.

Use the lifting mechanism (see Fig. 1.) to set the required working height.

Release the machine tilt lock (see Fig. 1.) to enable the working height of the machine to be adjusted to suit the material to be machined.

When working it is advisable to leave all the moving axes on the machine (Fig. 4) free. This prolongs the lifetime of the machine, enabling it to better adapt to any unevenness or deformations in the metal.

After the machine has been moved to the material, it is also advisable to turn the handle to adjust the lifting mechanism (see Fig. 1.) to a position approx. 50mm lower. This enables the working height of the machine to be automatically corrected if necessary.

 **CAUTION !!** When the machine is approaching the end of the material, the lifting mechanism (see Fig. 1) needs to be returned to the current working height of the machine.

 **CAUTION!!** If the workplace floor is uneven or if the bevelled material is not level or otherwise deformed, the machine cannot be guaranteed to work properly. The machine may be overloaded, stop working or move away from the material. This may damage the machine.

**TIP!!** If the conditions for using the manipulator together with the UZ15 are unsuitable for the above reasons, after the machine has moved to the material the 3D Manipulator may be disconnected from the machine. The machine then moves along the material by itself. Before it reaches the end of the material the 3D Manipulator must be reconnected to the machine, otherwise there is the risk of the machine falling!

After the top edge of the material has been bevelled, (if bevelling on both sides) the machine can be rotated by 180° and, after adjusting the working height and level, a double-sided bevel may be performed. This means there is no need to move the machined material. If you want to rotate the machine in the manipulator, the lock on the rotating mechanism needs to be released.

### **Procedure for machining smaller parts.**

The 3D Manipulator can be used as a work station for a bevelling machine.

Use the lifting mechanism (see Fig. 1.) to set the bevelling machine at the required working height and lock the 3D Manipulator in all axes. The machine is now ready for use as a stationary bevelling unit.

## **Safety regulations:**



### **Caution:**

#### **Operators must always:**

1. Ensure that all safety covers are fitted and that safety devices are function before starting to use the machine.
2. Avoid wearing clothing or jewellery that could get caught in moving parts.
3. Wear the approved safety footwear, such as boots with a non-slip tread, ear protectors and goggles.
4. Apply safety standards, ensure that they are always followed and. If in doubt, always re-check the user manual before starting to use the machine.
5. Contact the machine supplier if unable to rectify any defects and thus use the machine safely.
6. It is essential to comply with all the applicable safety regulations defining how to work with machine tools.
7. The 3D Manipulator may only be used by professionally qualified and trained staff.
8. Work only in a dry, well-ventilated environment.
9. Ensure that the power cable does not come into contact with the bevelling machine or 3D Manipulator.
10. When using the 3D Manipulator, vibrations can cause nuts and screws to come loose. This can cause the device to work incorrectly and could result in more serious damage. It is therefore essential to constantly check that all nuts and screws are tight.

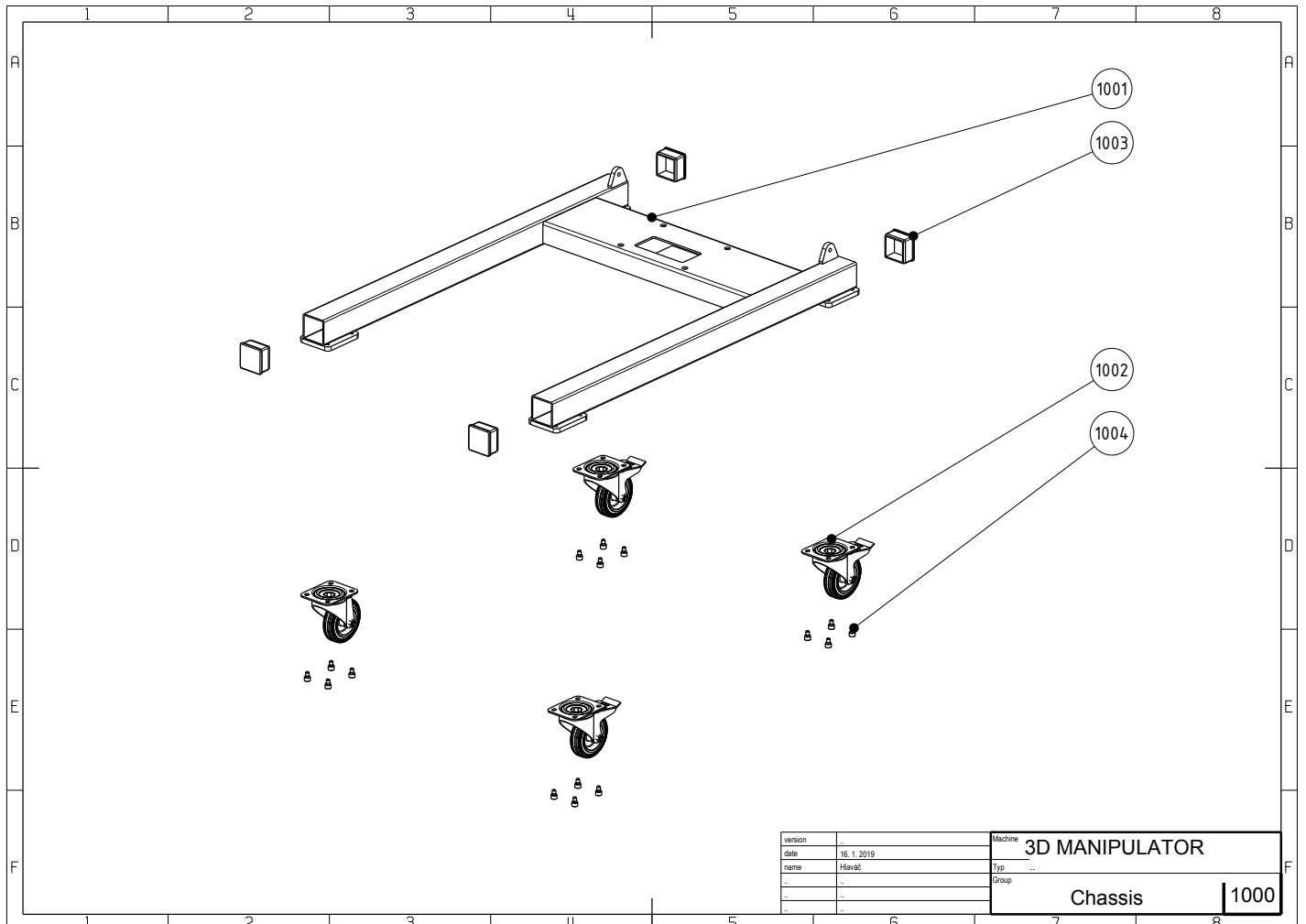

### 3D MANIPULATOR SPARE PARTS

drawing no. 1000 Chassis

Number	Fig	Part name	Note	Pcs
1930.1001	1001	Frame		1
1930.1002	1002	Wheel		4
1930.1003	1003	Plug		4
1930.1004	1004	Screw		16



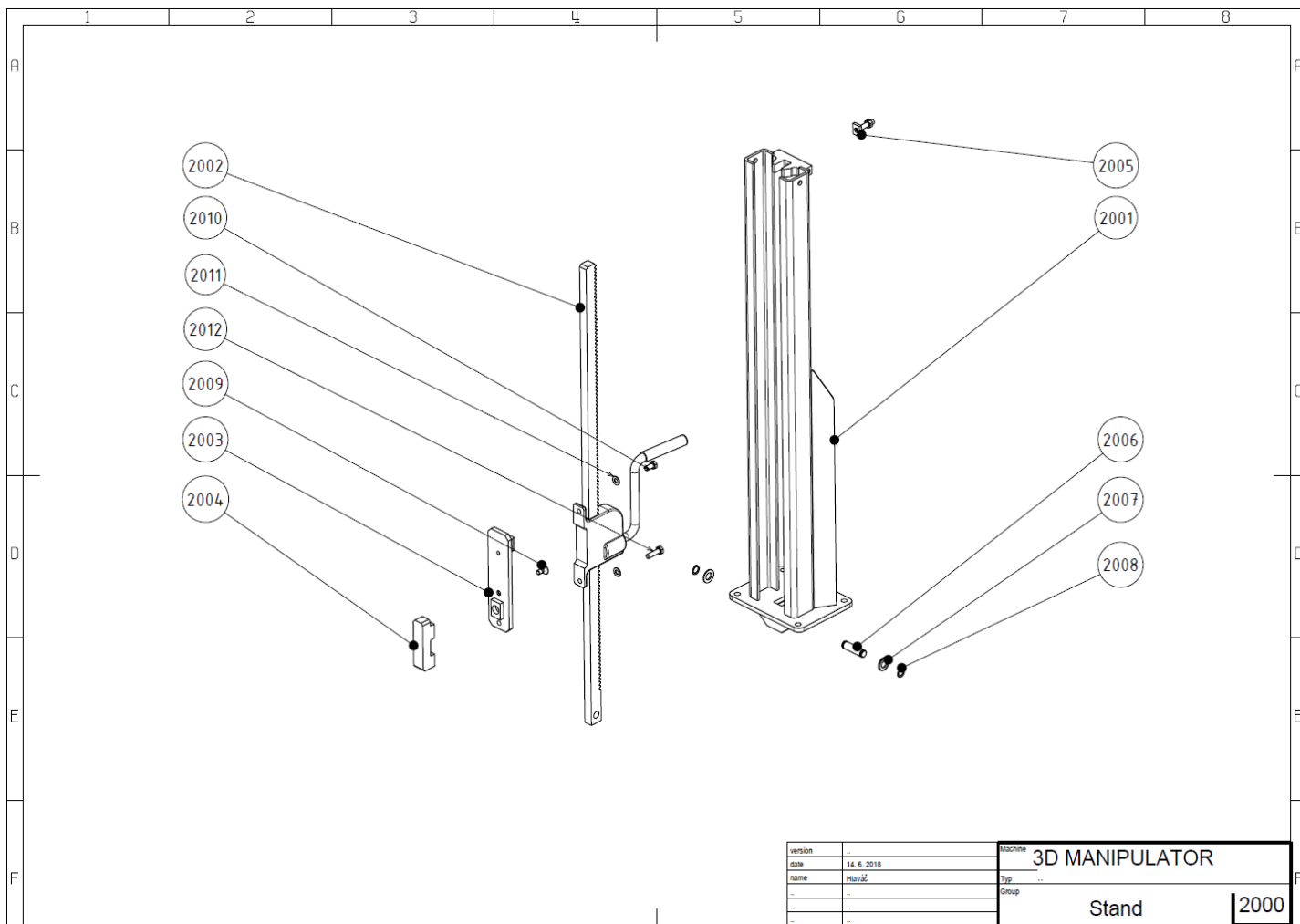

### 3D MANIPULATOR SPARE PARTS

drawing no. 2000 Stand

Number	Fig	Part name	Note	Pcs
1930.2001	2001	Post		1
1930.2002	2002	Jack		1
1930.2003	2003	Adapter		1
1930.2004	2004	Stop		1
1930.2005	2005	Adjusting screw		1
1930.2006	2006	Pin		1
1930.2007	2007	Washer		2
1930.2008	2008	Retaining ring		2
1930.2009	2009	Sunk screw		1
1930.2010	2010	Screw		1
1930.2011	2011	Washer		2
1930.2012	2012	Screw		1

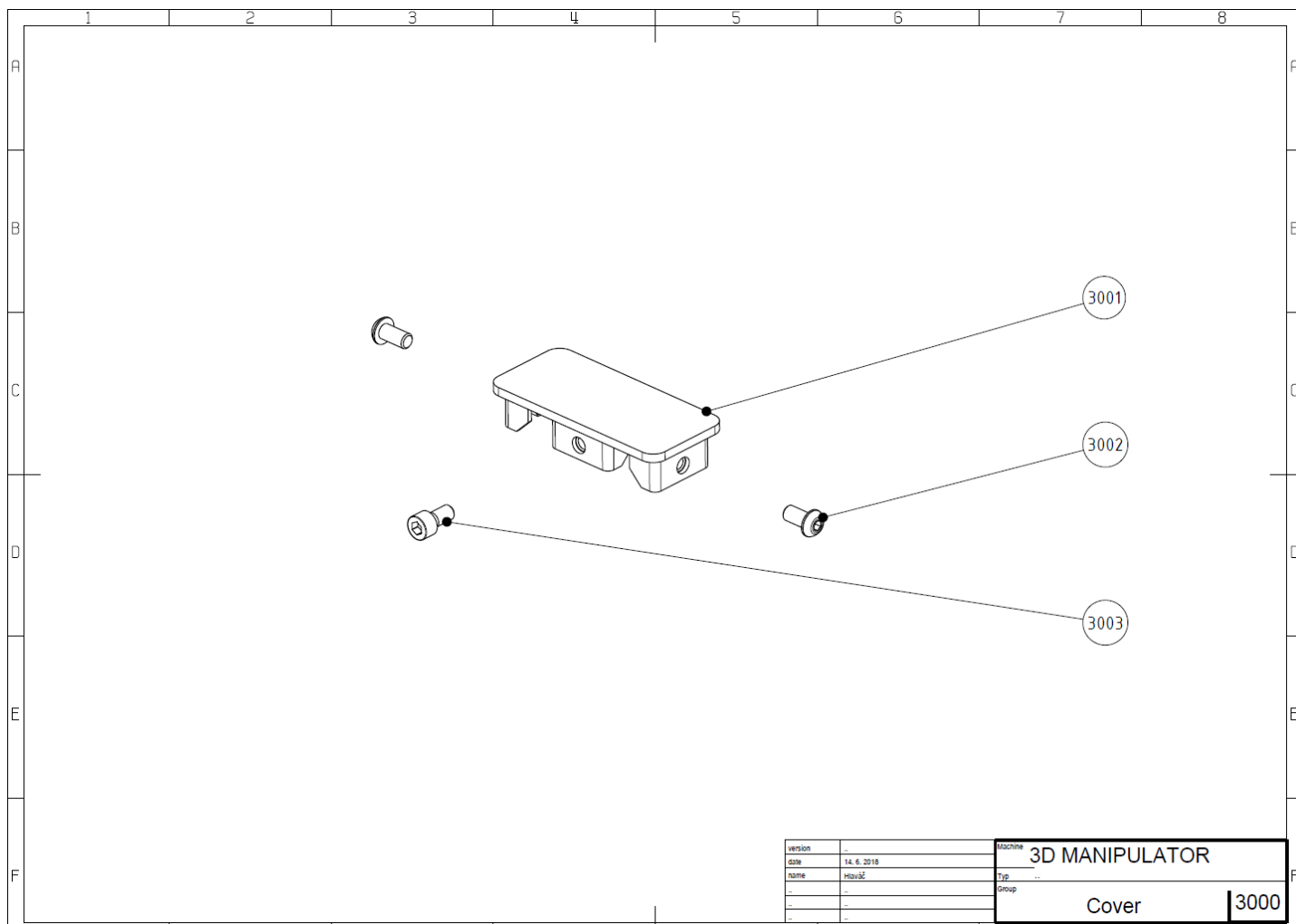

# 3D MANIPULATOR SPARE PARTS

drawing no. 3000 Cover

Number	Fig	Part name	Note	Pcs
1930.3001	3001	Cap		1
1930.3002	3002	Screw		2
1930.3003	3003	Screw		1

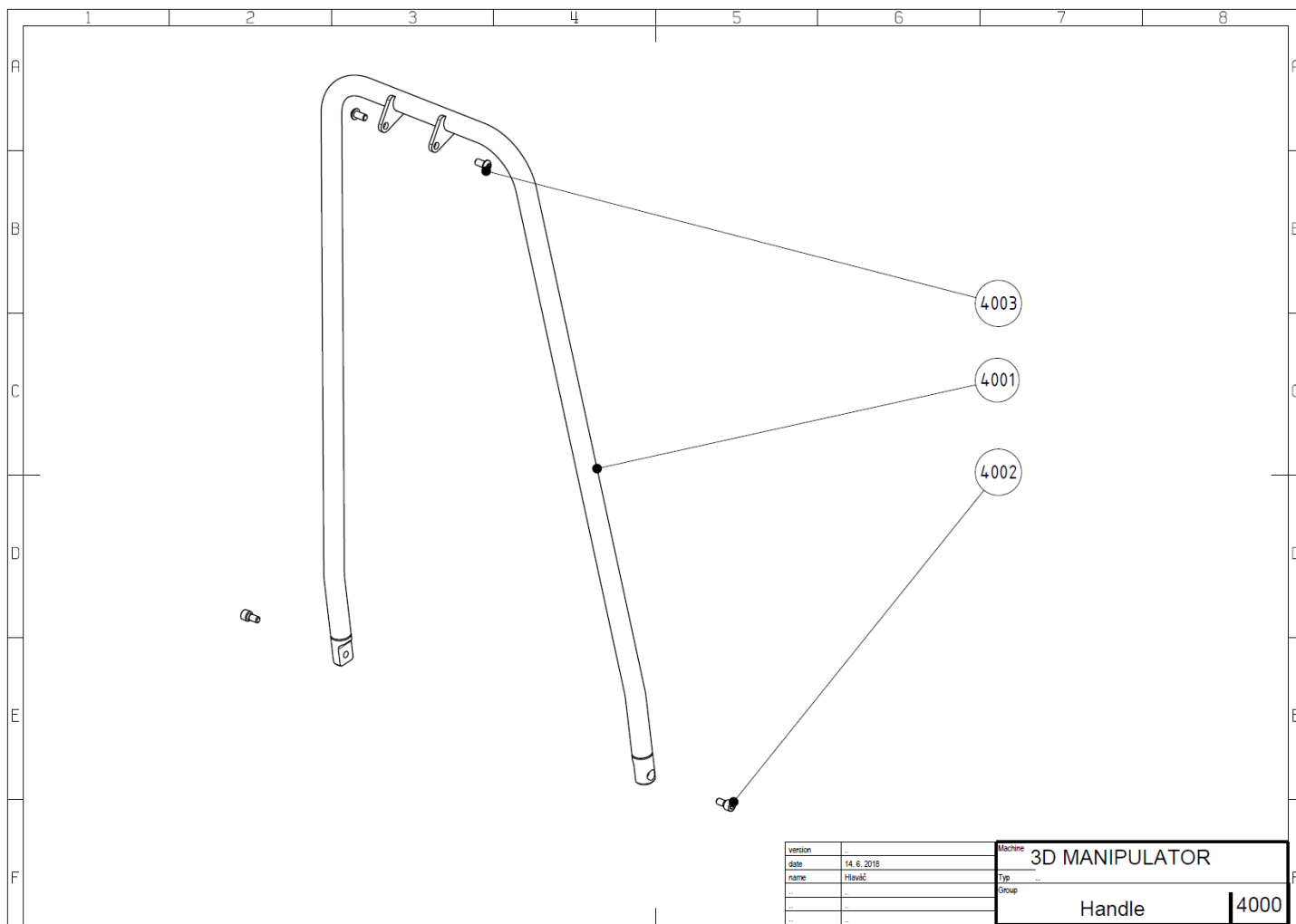

### 3D MANIPULATOR SPARE PARTS

drawing no. 4000 Handle

Number	Fig	Part name	Note	Pcs
1930.4001	4001	Grab bar		1
1930.4002	4002	Screw		2
1930.4003	4003	Screw		2



**Only for older versions manufactured prior to 2018**

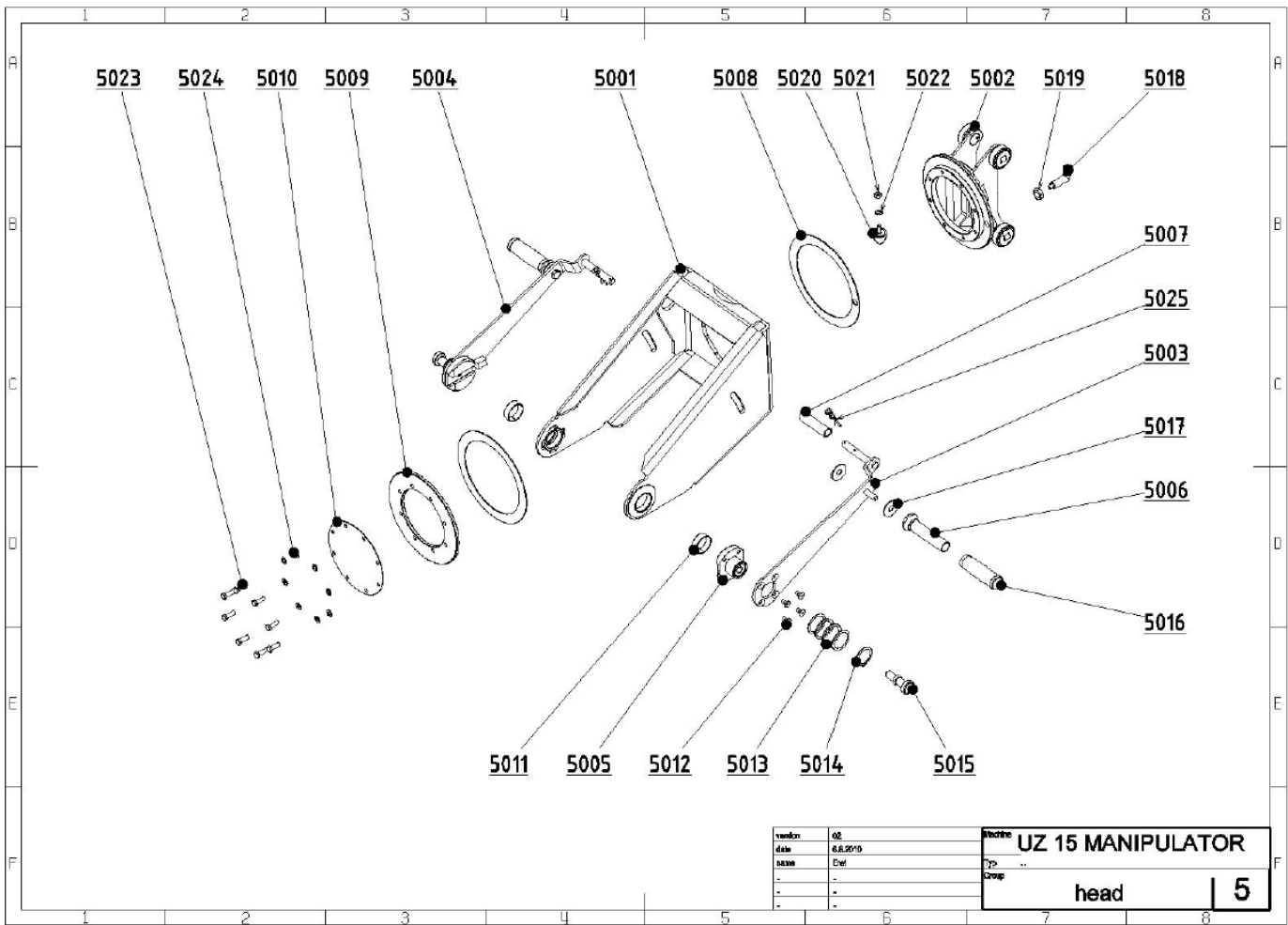

**3D MANIPULATOR SPARE PARTS**

drawing no. 5000 old version

Number	Fig	Part name	Note	Pcs
1930.5001	5001	Body	Older version	1pc
1930.5002	5002	Trolley		1pc
1930.5003	5003	Lever left	Older version	1pc
1930.5004	5004	Lever right	Older version	1pc
1930.5005	5005	Retainer		2pc
1930.5006	5006	Handle	Older version	2pc
1930.5007	5007	Connection tube	Older version	1pc
1930.5008	5008	Ring		2pc
1930.5009	5009	Flange		1pc
1930.5010	5010	Cap		1pc
1930.5011	5011	KU sleeve		2pc
1930.5012	5012	Sunk Screw		8pc
1930.5013	5013	Calibration washers	Older version	4pc
1930.5014	5014	Retaining ring		2pc
1930.5015	5015	Locking pin		2pc
1930.5016	5016	Rubber covering	Older version	2pc
1930.5017	5017	Washer		2pc
1930.5018	5018	Locking cam pin		1pc
1930.5019	5019	Nut		1pc
1930.5020	5020	Buffer		1pc
1930.5021	5021	Nut		1pc
1930.5022	5022	Washer		1pc
1930.5023	5023	Screw		8pc
1930.5024	5024	Washer		8pc
1930.5025	5025	Split pin	Old version	2pc

A copy of this manual is supplied with each 3D Manipulator  
All rights reserved.  
No part of this publication may be reproduced without the prior consent of N.KO

**Manufacturer's and Distributor's Address:**

***N.KO spol. s r.o.  
a Member of Richtr Group***

***Táborská 398/22  
293 01 Mladá Boleslav  
Czech Republic – Europe Union***

***Phone: +420 326 772 001  
email: nko@nko.cz***

**USA Distributor's Address:**

***BEVELER USA INC.  
a Member of Richtr Group  
Business Office, Workshop, Warehouse***

***328 14th Street  
Ambridge, PA 15003***

***Toll Free Number: 1-800-973-1138  
Phone Ambridge (PA) office: 1-412-452-2563  
email: service@bevelerusa.com***